

Silverline

TROUBLE SHOOTING GUIDE - Victor Softener Systems (Timed Models)

Under normal circumstances Silverline water softeners run trouble free for many years.

Occasionally a service call may be necessary though in most cases any problems are operational rather than due to defective parts, and can easily be resolved by the user.

If you are experiencing problems with your unit, please check carefully all the points listed in the following document before requesting a call. If you have any queries please telephone our technical department for assistance. User problems are not covered by guarantee and are chargeable.

TROUBLESHOOTING

Problems can be divided into two main groups, programming or physical. In general if the softener is using salt, but no soft water is being produced the problem is due to incorrect programming.

If the unit has been working well and suddenly stops, the problem is normally physical e.g. a blockage.

1. Ensure the unit is plugged in, that there is power to the unit and that the electrical lead is firmly plugged into the machine.
2. Check that the timer is set at the correct time of day, and is moving forward correctly over a 24 hour period (if not it may indicate a timer motor issue).
3. A softener needs to clean itself at intervals or it will be unable to collect the hard water salts. This is controlled by the valve program so ensure the correct number of pins is pulled out on the skipper wheel.
4. Check that water can actually pass through the softener by ensuring the inlet and outlet valves are fully open, and the bypass valve fully closed.
5. If water cannot flow freely from the machine it cannot clean properly so check there are no kinks or blockages in the drain hose.
6. Check the salt compartment is at least half full with tablet salt.
7. A drop in water pressure can cause significant trouble as the softener does require a minimum pressure to operate. Water pressure can vary at any time so even if the softener has been working for some time this cannot be ruled out. There is however some flexibility, and removing the brass 'tear drop' then turning the drain flow adjuster 90° to the open position, will allow the softener to function at lower pressure. If low pressure is the problem the unit should be left on this setting.

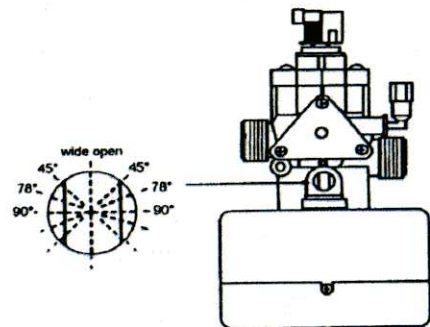

8. Occasionally there are particles of grit in the water supply which can block the injector or the injector filter. The injector is located on top of the valve. To clean proceed as follows:
 - a. Turn off the power and water.
 - b. Remove the 3 screws holding the injector in place.
 - c. Lift off the injector cover plate.
 - d. Remove the injector, injector gasket and injector filter.
 - e. Carefully clean the injector disc and injector filter.
 - f. Replace the injector filter.
 - g. Replace the injector gasket; mind the alignment over the alignment post.
 - h. Replace the injector; mind the alignment over the alignment post.
 - i. Replace the injector cover plate.
 - j. Replace the 3 screws and tighten evenly.
 - k. Turn on the water and electricity.

